



Japan Grand Prix International Orchid Festival

Festival Guide

Saturday, February 19-Sunday, February 27, 2011

※ These contents may change. Please confirm the details in the Information for Exhibitors to be sent in November.

As of July 2010

Japan Grand Prix International Orchid Festival Head Office

Table of Contents

| | |
|-------|---|
| P. 2 | 1. Objective of Festival |
| P. 3 | 2. Outline of Festival |
| P. 4 | 3. Schedule |
| P. 5 | 4. Exhibits |
| P. 6 | 5. Division I Individual / Division II Fragrance |
| P. 8 | 6. Division III Display |
| P. 12 | 7. Division IV Flower Arrangement, V Arts and Crafts & VI Miniature Orchid Garden |
| P. 18 | 8. Sales |
| P. 22 | 9. Orchid Export & Import |
| P. 23 | 10. Admission Tickets |

Popularizing a love of flowers and nature through orchids

We started the Japan Grand Prix International Orchid Festival in 1991. Thanks to your support and cooperation, the festival has developed into a flower event drawing international attention as a harbinger of the arrival of spring. We very much appreciate your contribution. In 2010 we celebrated its 20th anniversary.

We are planning an attractive festival full of new approaches and discoveries for the next year. We hope you execute works that connect with all who attend the festival. We are aiming to be a bridge for international exchange and familiarization and the improvement of breeding technology through the exhibition of orchids from Japan and abroad. At this year's Japan Grand Prix International Orchid 2010, there were attractive, high-quality works from 19 countries, and we hosted a large number of visitors from Japan and abroad. The theme of the 20th festival was "Orchids: Cordial Hospitality." We had opportunities to meet with attendees, who included people without knowledge of orchids as well as orchid lovers, and a chance to feel more familiar with orchids and realize how wonderful it is to have orchids in our lives. It was a wonderful occasion in which new friendships were formed through orchids.

There were roughly 100,000 orchids on display, including 1,041 plants entered for competition in the Individual and Fragrance divisions, 361 exhibits in the Display, Flower Arrangement divisions and a Miniature Orchid Garden. We believe that the attendees thoroughly enjoyed these works and were fascinated by the variety of orchids.

Planning the Japan Grand Prix International Orchid Festival 2011, we are cooperating with orchid lovers and growers in Japan and abroad with the hope of extending flower-loving culture to as many people as possible by offering an environment that encourages familiarity with flowers and nature through the appreciation of orchids.

Strengthening international cultural exchange through orchids

The festival, with its variety of tropical, temperate, oriental and Japanese orchids exhibited by orchid lovers and growers from the Americas, Europe, Pacific, Africa, and Asia together with domestic exhibitors from Hokkaido to Okinawa, provides opportunities to exchange information on techniques and other topics, and has contributed to the strengthening of mutual friendships over the years.

It also is a forum that gives us the chance to increasingly enjoy diverse works of flower arrangement, crafts and other arts. These creations are expanding the range of flower culture and help us to feel relaxed and at home in public spaces. As we organize the festival, we hope this opportunity will inspire and promote diverse exchanges centered on orchids among attendees and exhibitors from many countries.

The Japan Grand Prix – An authoritative orchid contest

In 2010 the Japan Grand Prix was awarded to the wonderful orchid, *Den. fimbriatum* var. *oculatum* 'Long Well.' The chairman of the Judging Committee stressed that the flowers were of the highest standard in the world and offered lavish praise for the overall level of the entries in the Individual Division category and other displays.

As organizers of this festival, we aim to boost its standing every year by promoting admirable entries in each division, awarding the Japan Grand Prix to the finest and spreading flower culture throughout the world.

Theme: Enjoy orchids, enjoy through orchids

The theme for the JGP 2011 is "Enjoy orchids, enjoy through orchids."

| | |
|--|---|
| Title: | Japan Grand Prix International Orchid Festival 2011 (Abbreviation: JGP 2011) |
| Hosts: | JGP2011 Working Committee [The Yomiuri Shimbun, NHK (Japan Broadcasting Corporation), JGP Organizing Committee] |
| Supporters (tentative): | Foreign Ministry; Economy, Trade and Industry Ministry; Agriculture, Forestry and Fisheries Ministry; Environment Ministry; Tokyo Metropolitan Government; National Science Museum; the American Orchid Society; the Royal Horticulture Society; and the World Orchid Conference Trust |
| Cooperating Organizations (tentative): | The Japan Orchid Growers Association, the Japan Horticultural Society, the Japan Garden Center Association, the Japan Flower Wholesale Market Association, the Orchid Division of the Japan Flower Growers Association, the Japan Home Gardening Association, the All Japan Florists Association, the Japan Florists' Telegraph Delivery Association, the Japan Oriental Orchid Society, the Japan Flower Promotion Center, the Nippon Flower Designers' Association, the Japan branch of the Royal Horticultural Society, Preserved Flower Council Japan, and other orchid societies |
| Sponsors: | To be determined |
| Special Cooperation: | Tokyo Dome |
| Planning and Operating: | THE YOMIURI SHIMBUN, Head Office in Tokyo |
| Venue: | Tokyo Dome 1-3-61, Koraku, Bunkyo-ku, Tokyo |
| Dates: | Preview: Friday, February 18, 2011 Open to public: Nine days from Saturday, February 19 to Sunday, February 27, 2011 |
| Hours: | 10 a.m. - 5:30 p.m. Entrance closes at 4:30 p.m. ※ Extended hours to be determined. |
| Exhibitors: | Orchid growers and associations, orchid lovers and societies, enterprises and societies related to the gardening industry, etc. |
| Organizer's Exhibitions: | To be determined |
| Judging Divisions: | Division I Individual, Division II Fragrance, Division III Display, Division IV Flower Arrangement, Division V Arts and Crafts, Division VI Miniature Orchid Garden |
| Prizes: | Total amount of prize money: ¥12,500,000 (tentative) |
| Number of Countries: | Approximately 20 countries and regions |
| Number of Orchids: | Approximately 3,000 varieties Approximately 100,000 plants (tropical, temperate, oriental and Japanese orchids) |
| Events at Site: | To be determined |
| Incidental Projects: | Activity of Growing Orchids, Orchid Forum, etc |
| Admission Fee: | Advance: adults ¥1,800 At the door: adults ¥2,000 Evening Ticket ¥1,500 (3 p.m.-) sold only at the Tokyo Dome entrance on the day Primary school children or younger: Free |
| Ticket Sales: | Sales of advance tickets: from Wednesday, December 1, 2010 through Friday, February 12, 2011 Available on the JGP Web site (in Japanese), Ticket Bureau, etc. |

* The above information may change. Please confirm the details in the guide book to be sent in November.

For further information

The Japan Grand Prix International Orchid Festival Head Office

c/o THE YOMIURI SHIMBUN 1-7-1, Otemachi, Chiyoda-ku, Tokyo, 100-8055, Japan

Contact: Nanako Terakubo

Phone: +81-3-6739-6940 Fax: +81-3-3216-8568

tera9130@yomiuri.com

Main schedule

| Year | Month | Date | Div. III | Sales | Div. IV | Div. V | Div. VI | Div. I, II | | |
|------|-----------|----------------------|--|------------------------------------|---------------------|---------------------------|---------|------------|--|--|
| 2010 | August | 2 | Receipt of applications begins | | | | | | | |
| | | 27 | Deadline for domestic application | | | | | | | |
| | September | 3 | Deadline for overseas application | | | | | | | |
| | October | | Layout of the booths | | | | | | | |
| | November | | | Orientation meeting | | | | | | |
| | | 12 | | | | Deadline for applications | | | | |
| | | 26 | Deadline for applications for details | | Preliminary judging | | | | | |
| | December | 1 | Start of Advanced Tickets Sales | | | | | | | |
| 24 | | Deadline for entries | | Mid-December: Deadline for entries | | | | | | |
| 2011 | January | | Middle to end of January: Final notice | | | | | | | |
| | February | 15 | Basic booth setup by organizer | | | | | | | |
| | | 16, 17 | Setting up, entry registration for Div. I, II, IV, V and VI. | | | | | | | |
| | | 18 | Judging, press announcement, opening ceremony and preview | | | | | | | |
| | | 19-27 | Japan Grand Prix International Orchid Festival 2011 open to public | | | | | | | |
| | | 27, 28 | Dismantling and removal | | | | | | | |

Schedule during the festival

| | | |
|------------------------|--|--|
| Tuesday, February 15 | 7 a.m.-midnight | Basic booths setup by organizer |
| Wednesday, February 16 | 7:30 a.m.-11 p.m. 4 p.m.-7 p.m. | Setup Registration for judging |
| Thursday, February 17 | 7:30 a.m.-11 p.m. 11 a.m.-3 p.m. | Setup Registration for judging |
| Friday, February 18 | 9 a.m. -3 p.m. 3:15 p.m.-3:45 p.m. 4:30 p.m.-5:10 p.m. 4:35 p.m.-5:10 p.m. 5:10 p.m.-6:30 p.m. 6:30 p.m.-8:30 p.m. 8:45 p.m.-10 p.m. | Judging Press announcement of the judging results Preparation for sales in preview by vendors Opening ceremony, award presentations Special preview Preview Adjustment by exhibitor, additional delivery |
| Saturday, February 19 | 10 a.m.-5:30 p.m. | Open to public |
| Sunday, February 20 | 10 a.m.-5:30 p.m. | Open to public |
| Monday, February 21 | 10 a.m. -5:30 p.m. | Open to public |
| Tuesday, February 22 | 10 a.m. -5:30 p.m. | Open to public |
| Wednesday, February 23 | 10 a.m. -5:30 p.m. | Open to public |
| Thursday, February 24 | 10 a.m. -5:30 p.m. | Open to public |
| Friday, February 25 | 10 a.m. -5:30 p.m. | Open to public |
| Saturday, February 26 | 10 a.m. -5:30 p.m. | Open to public |
| Sunday, February 27 | 10 a.m. -5:30 p.m. 6:30 p.m.- | Open to public Exhibit dismantling and removal by exhibitors |
| Monday, February 28 | -11a.m. 8 a.m. -10 p.m. | Dismantling and removal by exhibitors Booth dismantling by organizer |

| |
|--|
| Additional delivery times: 8 a.m.-9:30 a.m. 5:45 p.m.-8 p.m. |
|--|

*The dismantling and removal work begins after the festival concludes on February 27 at 6:30. p.m. Plants are to be returned to exhibitors after ownership has been confirmed by the festival organizer.

*The removal of plants or works during the event period is not permitted. In case plants become inappropriate for display, they will be removed on an exceptional basis by the festival organizer.

*The topic of extending the opening hours yet to be determined.

1. Exhibits

All exhibits accepted by the Working Committee are subject to judging, with the exception of special exhibits by the organizer. This festival is to be held in strict accordance with the Convention on International Trade in Endangered Species of Wild Fauna and Flora, aiming for the development and conservation of healthy orchids worldwide. Therefore, all plants exhibited, judged and sold must be propagated plants. Only the orchids imported under the CITES procedure are acceptable. However, plants propagated artificially from those plants imported before the application of the convention (January 17, 1990) also are acceptable.

Please submit copies of CITES certification to the head office. The Committee reserves the right to reject the entries of plants that are restricted by CITES or those that have been uprooted from nature, and the right to inform authorities concerned in such cases.

2. Judging Divisions

Division I: Individual (Japan Grand Prix candidates)

All types of orchids, including those of tropical, temperate, oriental and Japanese origin, are judged based on the orchids themselves. Orchids can be potted, cut flowers, or foliage plants.

Division II: Fragrance

All types of orchids, including those of tropical, temperate, oriental and Japanese origin, are judged based on their fragrance. Orchids can be potted or cut flowers.

Division III: Display

This division consists of displays of orchids, including those of tropical, temperate, oriental and Japanese origin. The Amateur Class (entered by orchid societies and individuals that are accredited by the JGP Committee) and Open Class (entered by those other than Amateur Class) are judged separately.

* As for the Amateur Class Displays, more than half the plants in the exhibit must be cultivated by the amateur entrants themselves.

Division IV: Flower Arrangement

Division IV consists of flower arrangements using orchids: Works are divided into Interior Design, Table Arrangement, and Bouquets. Each type is judged separately. Entries are submitted by the public. There is preliminary judging in advance, and only those works that pass this stage go on to the judging at the Tokyo Dome.

Division V: Arts and Crafts

Works using orchids as subjects or materials.

There are seven categories: Paintings, Botanical Art, Photographs, Art Flowers, Preserved Flowers, Pressed Flowers and Dried Flowers, and other works. Entries are submitted by the public. There is preliminary judging in advance, and only those works that pass this stage go on to the judging at the Tokyo Dome.

Division VI: Miniature Orchid Garden

Mixture of plants, including rooted orchids and other green plants, and possibly also ornaments, are arranged in containers.

Display size: Within width 50 cm x depth 50 cm x height 100 cm

Entries are submitted by the public. There is no preliminary judging.

Contents of Exhibit

◆Div. I Individual →Open to all tropical, temperate, oriental and Japanese orchids (potted, cut flowers and hageimono*)

◆Div. II Fragrance→Open to all tropical, temperate, oriental and Japanese orchids (potted and cut flowers).

*Hageimono: Oriental or Japanese foliage orchid plants

Categories

| Div. I Individual | Div. II Fragrance |
|--|--|
| Tropical, Temperate | Tropical, Temperate |
| A. <i>Cattleya</i> and its alliance | 1. <i>Cattleya</i> and its alliance |
| B. <i>Paphiopedilum</i> and its alliance | 2. <i>Dendrobium</i> and alliance (excluding <i>Den. moniliforme</i>) |
| C. <i>Phalaenopsis</i> and its alliance | 3. <i>Phalaenopsis</i> species, their hybrids and intergeneric hybrids |
| D. <i>Oncidium</i> and its alliance | 4. <i>Lycaste</i> and its alliance |
| E. <i>Cymbidium</i> and its alliance (excluding oriental genera) | 5. Other genera and their intergeneric hybrids |
| F. <i>Dendrobium</i> and its alliance (excluding <i>Den. moniliforme</i>) | |
| G. <i>Lycaste</i> , <i>Anguloa</i> , <i>Ida</i> and their alliance | Oriental and Japanese Genera |
| H. Other genera | 6. <i>Cym.</i> Single Flower |
| | 7. <i>Cym. nishiuchianum</i> , <i>Cym. Kanran</i> and other multi-florals |
| I. Oriental | 8. <i>Cym. sinense</i> , <i>Cym. x nishiuchianum</i> and hybrids involving <i>Cym. sinense</i> or <i>Cym. x nishiuchianum</i> , (excluding such hybrids involving tropical or temperate orchids) |
| <i>Cym. goeringii</i> (flowering) | 9. <i>Calanthe</i> (excluding hybrids with tropical or temperate genera) |
| Hageimono | 10. <i>Den. moniliforme</i> , <i>Neof. falcata</i> and other orchids of Japanese origin |
| Other oriental orchids | 11. Hybrids of tropical or temperate orchids and oriental orchids, and hybrids of tropical or temperate orchids and Japanese orchids |
| J. Japanese | |
| <i>Neofinetia falcata</i> (flowering and hageimono) | |
| <i>Dendrobium moniliforme</i> | |
| <i>Calanthe</i> | |
| Other orchids of Japanese origin | |

Please refer to the Guide Book for Exhibitors for further divisions within these categories.

Awards

Div. I Individual

| Judging Category | Award | No. | Prize Money(yen) | prize | Judging Method |
|-----------------------------------|-----------------------|-----|------------------|--|--|
| Ribbon Award | Blue Ribbon | 41※ | — | Blue Ribbon | Entries are divided into 41 categories. A Blue Ribbon is awarded in each category for first place, a Red Ribbon for second place and a White Ribbon for third place. |
| | Red Ribbon | | — | Red Ribbon | |
| | White Ribbon | | — | White Ribbon | |
| Trophy Award | Trophy Award | 41※ | — | Certificate, Trophy | Trophies are awarded to Blue Ribbon winners. |
| Division Award | Japan Grand Prix | 1 | ¥2,000,000 | Certificate, Trophy, Supplementary Prize | Winners of these four awards are selected by all the judges from among Trophy Award winners. |
| | Award for Distinction | 1 | ¥500,000 | Certificate, Trophy | |
| | Merit Award | 1 | ¥200,000 | Certificate, Trophy | |
| | Encouragement Award | 10 | ¥50,000 | Certificate | |
| Special Award By AOS, RHS and WOC | AOS Trophy | 1 | — | AOS Trophy | Honors the grower of the specimen plant showing the greatest skill in cultivation of an oriental and Japanese orchids, selected from the Blue Ribbon-winning plants |
| | RHS Trophy | 1 | — | RHS Trophy | Honors the grower of the specimen plant showing the greatest skill in cultivation of temperate or tropical orchids, selected from the Blue Ribbon-winning plants |
| | WOC Trophy | 1 | — | WOC Trophy | Honors the grower of the best species orchid selected from the Blue Ribbon-winning plants |

*Judging procedures may change. Information on changes will be sent separately.

*The number of Ribbon Awards may change.

All entries in Division I Individual also will be considered for gold, silver and bronze medals and a Certificate of Cultural Merit. Medals are subject to fees.

Div. II Fragrance

| | | | | | |
|----------------|-----------------------|----------|----------|---------------------|---|
| Ribbon Award | Ribbon Award | up to 20 | — | Ribbon | Entries are divided into 20 categories. Up to ten entries are chosen from among tropical and temperate orchids and up to 10 entries from among oriental and Japanese orchids. |
| Trophy Award | Trophy Award | up to 8 | — | Certificate, Trophy | Up to four entries are chosen from among ribbon winners in tropical and temperate and up to four entries from among ribbon winners in oriental and Japanese. |
| Division Award | Award for Excellence | 1 | ¥200,000 | Certificate, Trophy | These division awards are selected from among the above eight trophy (at maximum) award winners. |
| | Award for Distinction | 1 | ¥100,000 | | |
| | Merit Award | 1 | ¥50,000 | | |
| | Encouragement Award | 2 | ¥30,000 | Certificate | |
| Special Award | Special Award | up to 3 | — | Certificate | — |

How to Apply

Complete the entry form and submit it to the reception desk in Tokyo Dome on February 16 or 17. The registration fee is ¥1,000 per plant.

It is not necessary to apply in advance. IDs are supplied at the entrance of Tokyo Dome on February 16 and 17. Invitation tickets for the Preview Show (two tickets per exhibitor) are provided after plants are registered. Discount tickets for exhibitors are available only after registration.

Schedule

| | |
|--|--|
| February 16, 4 p.m.-7 p.m. February 17 11 a.m.-3 p.m. | Registration of entries at reception desk in Tokyo Dome |
| February 18 | Judging, Results Announcement, Opening Ceremony, Awards Presentation |
| February 19-27 | Open to public |
| February 27, 6:30 p.m.- | Dismantling of exhibit, return of entries |

Notes

- ◆ All exhibits must have been cultivated.
- ◆ Only plants imported through the standard procedures for CITES Appendix I and II will be accepted. Submit copies of CITES to the show secretariat. If it is concluded that an exhibit obviously consists of plants taken from nature, it will not be accepted for judging. However, this restriction does not apply to orchids that are hybrids of plants acquired before the convention took effect on January 17, 1990, or were propagated artificially from plants acquired before the convention took effect.
- ◆ Plants without botanical names will not be accepted.
- ◆ Exhibited plants cannot be taken out of the venue or moved within the venue.
- ◆ If any statement on the application form is found to be false, the award will be confiscated and invalidated. (This does not apply to judging for medals.)
- ◆ If a clonal name is offensive to public order and morals, awards will be rescinded by decision of the Judging Operating Committee and the exhibitor will be asked to change the clonal name or remove the exhibit.
- ◆ You are requested to exhibit fresh flowers. Those in the final stage of blooming or not yet fully bloomed will be excluded from judging. Flowers must be free of disease, discoloration, damage and deformities. These requirements do not apply to Hageimono.
- ◆ Flowers must be in natural bloom. If the judges find any part of the flowers or scapes to be artificially modified or altered, the entry will be disqualified.
- ◆ Hybrid orchids are to be classified according to Sander's list in principle. For genera which have been reclassified recently, the previous genera names also may be used.
- ◆ Pots must be clean and fit for display.
- ◆ Large or unstable plants must be arranged so they are steady.
- ◆ If a plant needs supports to stand, the supports do not need to be removed for judging, but they must be easy to remove.
- ◆ We accept no responsibility for damage or accidents during delivery and display at the site. Please arrange for any necessary insurance. Consult delivery companies regarding damage or accidents during delivery.
- ◆ Though exhibits in the venue are maintained by the show organizer, we accept no liability in case of fire, theft and/or other accidents.
- ◆ The host may suspend or cancel the festival due to acts of God or other unavoidable reasons. In that case it will be announced in The Yomiuri Shimbun newspaper or on the Web site of JGP. The host will not provide compensation for any damage or loss suffered as a result of suspension or cancellation.
- ◆ Exhibits must be picked up on the last day.

Contents of Exhibit

- ◆ This division consists of displays decorated with orchids, including tropical, temperate, oriental and Japanese orchids.

Categories

For the first participation, exhibitor can not enter size A, B and C.

| 〈Amateur Class〉 →Organizations must be recognized as amateur groups by the organizing committee. More than half the orchids must have been cultivated by amateurs. | | | |
|---|----------|------|---|
| Group | Category | Size | Description |
| Tropical, Temperate | 1 | C | 〈Width〉6 m x〈Depth〉4 m=24m ² :〈height〉up to 5.4 m |
| | 2 | D | 〈Width〉4 m x〈Depth〉4 m=16m ² :〈height〉up to 5.4 m |
| | | E | 〈Width〉4 m x〈Depth〉2 m=8m ² :〈height〉up to 3.6 m |
| Oriental, Japanese | 3 | C | 〈Width〉6 m x〈Depth〉4 m=24m ² :〈height〉up to 5.4 m |
| | 4 | D | 〈Width〉4 m x〈Depth〉4 m=16m ² :〈height〉up to 5.4 m |
| | 12 | E | 〈Width〉4 m x〈Depth〉2 m=8m ² :〈height〉up to 3.6 m |
| 〈Open Class〉 →All those not belonging to amateur class. | | | |
| Group | Category | Size | Description |
| Tropical, Temperate | 5 | A | 〈Width〉10 m x〈Depth〉6 m=60 m ² :〈height〉up to 7.0 m |
| | | B | 〈Width〉8 m x〈Depth〉6 m=48 m ² :〈height〉up to 7.0 m |
| | 6 | C | 〈Width〉6 m x〈Depth〉4 m=24 m ² :〈height〉up to 5.4 m |
| | 7 | D | 〈Width〉4 m x〈Depth〉4 m=16 m ² :〈height〉up to 5.4 m |
| | 12 | E | 〈Width〉4 m x〈Depth〉2 m=8 m ² :〈height〉up to 3.6 m |
| Oriental, Japanese | 8 | A | 〈Width〉10 m x〈Depth〉6 m=60 m ² :〈height〉up to 7.0 m |
| | | B | 〈Width〉8 m x〈Depth〉6 m=48 m ² :〈height〉up to 7.0 m |
| | 9 | C | 〈Width〉6 m x〈Depth〉4 m=24 m ² :〈height〉up to 5.4 m |
| | 10 | D | 〈Width〉4 m x〈Depth〉4 m=16 m ² :〈height〉up to 5.4 m |
| | 11 | E | 〈Width〉4 m x〈Depth〉2 m=8 m ² :〈height〉up to 3.6 m |
| Overseas | 12 | T | Overseas Table Display 〈Width〉1.5 m x〈Depth〉1.5 m=2.25 m ² |

Awards

| Category | Award | No. | Prize Money (yen) | Consolation prize | Judging Method |
|--------------------------------|-------------------------------|----------|-------------------|---------------------|--|
| Trophy Award (Amateur Class) | Trophy awards (Amateur Class) | up to 65 | — | Certificate, Trophy | Entries are divided into categories (according to size) and judged. Up to 65 entries will be chosen. |
| Trophy Award (Open Class) | Trophy awards (Open Class) | | — | | |
| Division Award (Amateur Class) | Award for Excellence | 1 | ¥1,000,000 | Certificate, Trophy | Division awards are selected from among the trophy award winners. |
| | Award for Distinction | 1 | ¥500,000 | | |
| | Merit Award | 1 | ¥300,000 | | |
| | Merit Award Second Place | 1 | ¥200,000 | | |
| | Special Encouragement Award | 2 | ¥150,000 | | |
| | Encouragement Award | up to 15 | ¥70,000 | Certificate | |
| Division Award (Open Class) | Award for Excellence | 1 | ¥1,000,000 | Certificate, Trophy | Winners are selected from overseas entries, excluding Trophy Award winners. |
| | Award for Distinction | 1 | ¥500,000 | | |
| | Merit Award | 1 | ¥300,000 | | |
| | Merit Award/Second Place | 1 | ¥150,000 | | |
| | Special Encouragement Award | 2 | ¥100,000 | | |
| | Encouragement Award | 20 | ¥70,000 | | |
| | Overseas Encouragement Award | Up to 5 | ¥50,000 | Certificate, Trophy | |

| Category | Award | No. | Prize Money(yen) | Consolation prize | Judging Method |
|--------------------------|-----------------------|-----|------------------|---------------------|--|
| Judging of Modern Design | 1st place | 1 | ¥150,000 | Certificate, Trophy | All entries which register in the judging of Modern Design |
| | 2 nd place | 1 | ¥70,000 | Certificate | |
| | 3 rd place | 1 | ¥50,000 | Certificate | |

〈Judging of Modern Display〉

The aim of this division is to have a variety of displays in the show. Displays which must fit the concept of Modern Display – may be entered in this division. It is possible to receive awards in this division in addition to other conventional awards.

[Criteria of Modern Display]

Compositions of exhibit must be applied to living space (including terrace and balcony) and the image must be modern and futuristic. Visitors can apply the ideas to their own life. Items which give you an idea of living space must be used. (for example; chairs, tables, windows and mirror)

Natural style designed with natural wood will be excluded from this judging.

Only entries registered in this division will be judged. Entries must be E size or larger.

To enter this division, mark the square for “Judging of Modern Design” in the application.

Entries in this division will be announced at the end of September.

Display Subsidy

Exhibitors whose entries are accepted for judging in the Div. III Display and who conduct sales will receive a Display Subsidy according to the scale of the display, as specified below. Moreover, exhibitors in the Div. III Display qualify for a special discount fee for a sales booth. Please note that subsidies will not be paid for displays that are not accepted for judging. Subsidies will be paid during the duration of the show at the reception office for exhibitors.

| | C | D | E | Table Display |
|-------------------|----------|----------|---------|---------------|
| Display and Sales | ¥210,000 | ¥100,000 | ¥50,000 | ¥20,000 |
| Display only | ¥0 | ¥0 | ¥0 | ¥0 |

Display Booth

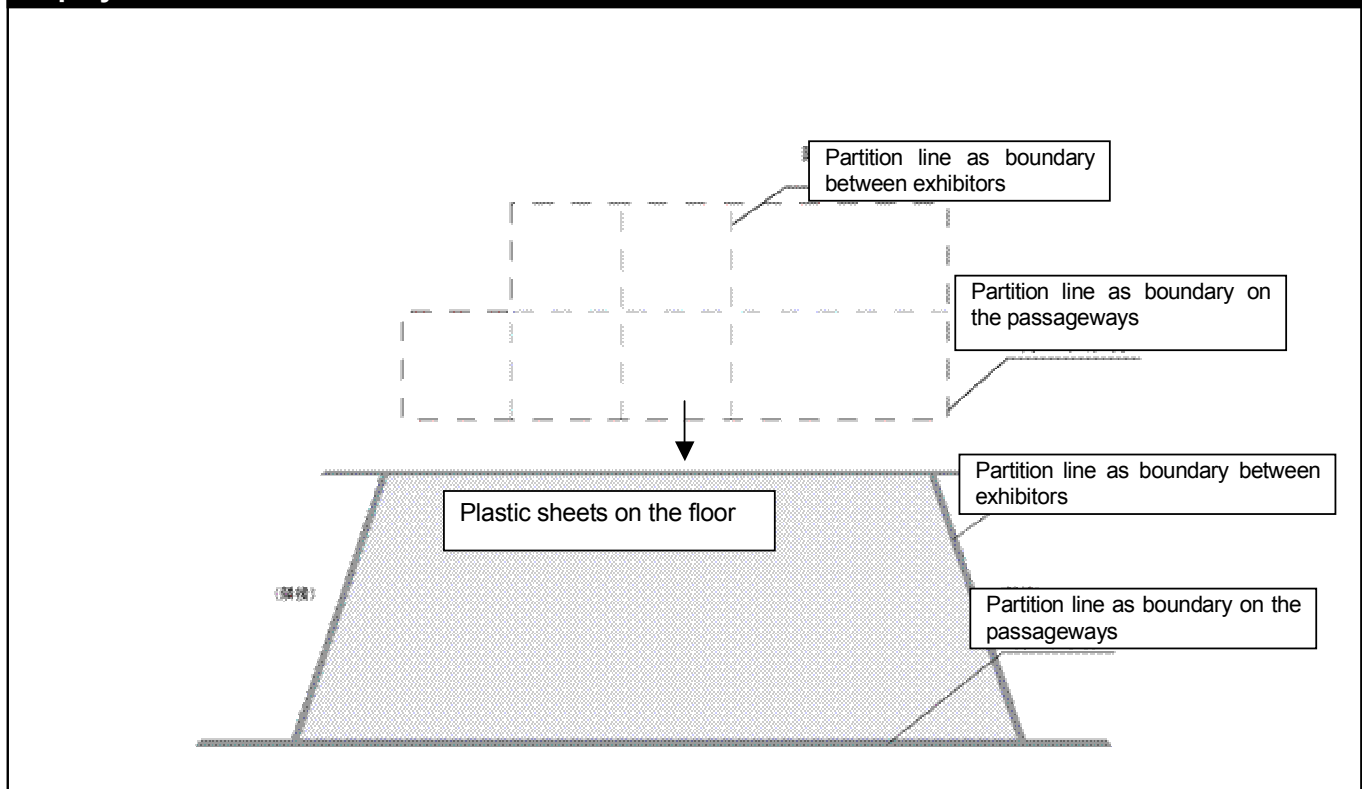

〈Display Booth〉

*Signboards will not contain “Co., Ltd” and “Unlimited” etc.

*Booths are partitioned with tape. No free foliage plants or logs will be provided. Should you need these items for partitioning, please order them through the application for details, which will be sent in November.

*If you use water, soil, Crypto moss, etc., make sure to protect the floor. Do not allow your display to extend into the passageways or adjoining displays.

*Crypto moss, bark, etc. are not provided free. Order them by application form for details.

*If you will be displaying panels on the border with adjoining displays, please discuss this in advance with your neighboring displayers. In case you provide the panels on your own, make sure to treat the surfaces.

*There is no stock space in the display area. We appreciate your understanding.

*Please leave the layout of the exhibition to our discretion. Changes cannot be made to the layout by exhibitors without permission.

〈Number of Application, Space adjustment〉

*You may be asked to change the size of your display as space is limited. Exhibitors who were awarded higher prizes in the previous year will be given preference. Should we need you to change a display's size, we will contact you by mid-October.

Exhibits

◆All exhibits must have been cultivated.

◆This Festival will be held in strict accordance with the Convention on International Trade in Endangered Species of Wild Fauna and Flora. Therefore, all plants exhibited, judged and sold must be cultivated plants. Only orchids imported through CITES I or II will be accepted. However, plants propagated artificially from plants imported before the application of the convention (January 17, 1990) will be accepted. Please submit copies of CITES I and II to the show secretariat.

◆If the decoration or title of the exhibit offends public order and morals, it will not be accepted.

◆PR materials (leaflets, brochures, etc) can not be placed in the display.

◆If a display does not meet the rules for judging divisions, you may be requested to improve or remove your display. In that case, it may fail to be entered for judging. If improvements are not made, subsidies will not be paid.

◆Plants entered for judging in the individual and fragrance divisions cannot be used in Div. III Display.

◆Displayed plants may not be sold during the festival.

Schedule

| | | |
|------|---------------------------------------|--|
| 2010 | August | Registration for Display and Sales A notice of confirmation will be sent upon receipt of application. |
| | August 27 | Deadline for Domestic Exhibitors for Application for Display and Sales |
| | September 3 | Deadline for Overseas Exhibitors for Application for Display and Sales |
| | Mid-October | Layout of Displays and Sales Booths |
| | November 1:30-3:30 p.m.. | Orientation Meeting for Domestic Exhibitors at THE YOMIURI SHIMBUN 1-7-1, |
| | Mid- November | Orientation Kits sent to Exhibitors Information for Display, Sales and Judging List of Exhibitors Application forms, etc. |
| | November 26 | Deadline for Application for Details |
| 2011 | Mid-January | Deadline for Final Confirmation of Orchid Delivery Schedule Information required regarding export schedules to Japan includes: dates, items to be shipped, number of items, method of shipping (including flight number, etc.), port of entry, etc. This information will be forwarded to transportation companies, customs and plant quarantine authorities for smooth clearance of customs and other import procedures. |
| | Mid-January | Final Notice Sent |
| | February 19 through February 27 | 【JGP 2011】 |

How to Apply

◆ Please fill in the Display Division/Sales booth application form and send it to the address below postmarked no later than September 3, 2010. Please send by post, fax or e-mail.

Japan Grand Prix international Orchid Festival Head Office c/o THE YOMIURI SHIMBUN

1-7-1 Otemachi Chiyoda-ku Tokyo 100-8055 Japan TEL +81-3-6739-6940 FAX+81-3-3216-8568

Garbage Disposal

Garbage must be separated into combustible and noncombustible materials, and designated garbage stickers placed on the garbage bags. Exhibitors should write their names on the stickers.

Stickers are also necessary when disposing of cardboard boxes. Bind cardboard boxes together for disposal; one sticker may be used for a maximum of 10 cardboard boxes. Stickers are available at the show office for ¥500 each.

Vendors with one booth will receive 10 stickers each for combustible and noncombustible garbage; vendors with two or more booths will receive 20 stickers each for combustible and noncombustible trash.

Notes

◆ PR activities in passageways and exhibit booths are prohibited.

◆ The organizer will monitor the temperature and humidity of the site. However, all exhibitors are requested to provide what care their plants require themselves; please try to maintain optimum conditions for your plants.

◆ Exhibitors must take care not to cause loud noises, excessive light or heat, dust, gas, unpleasant odors, vibrations or other disturbances.

◆ Place lighting equipment 30 cm away from the boundary line.

◆ Fire inspections will be carried out during the setup period and when the exhibit is open to the public. Persons responsible for displays are requested to make themselves available for these inspections.

◆ Decorations that are flammable, explosive or involve prohibited imports cannot be used. Please let us know in advance if the following materials will be used in a display or sales booth: Styrofoam, acrylic, nylon, plastic, Japanese paper, cotton, sliding-screen paper, straw, cloth, etc. These materials must be fireproofed.

◆ In principle, structures involving ceilings are not permitted. Please consult with organizers in advance.

◆ In case you use crossties, or sleepers etc., make sure to use those that do not smell of antiseptic or other substances.

◆ Make sure water does not leak from ponds and waterfalls.

◆ We accept no responsibility for damage or accidents during delivery and display at the site. Please arrange for any necessary insurance. Consult delivery companies regarding damage or accidents during delivery.

◆ Though exhibits in the venue are maintained by the show organizer, we accept no liability in case of fire, theft and/or other accidents.

◆ The host may suspend or cancel the festival due to acts of God or other unavoidable reasons. In that case, it will be announced in The Yomiuri Shimbun newspaper or on the Web site of JGP. The host will not provide compensation for any damage or loss suffered as a result of suspension or cancellation.

We are working to improve the Japan Grand Prix International Orchid Festival to attract more visitors. The exhibits in the Div. III Display are a very important part of these efforts, and we therefore would like to ask all exhibitors for their awareness and cooperation in presenting the finest displays possible.

Thank you very much for your understanding and cooperation.

Contents

Division IV: Flower Arrangement

Flower arrangements using orchids: Works are divided into Interior Design, Table Arrangement, and Bouquets. *Only fresh orchids can be used in this division.

Division V: Arts and Crafts

Arts and Crafts using orchids as subjects or materials.

There are seven categories: Paintings, botanical art, photographs, art flowers, preserved flowers, pressed and dried flowers, and other works.

Division VI: Miniature Orchid Garden

Various plants - including potted orchids and other green plants - and ornaments are arranged together.

Categories

Division IV. Flower Arrangement

There are three categories in the Div. IV Flower Arrangement.

*Please follow the regulations for works. Works we deem as not following the regulations will be excluded from judging.

1. Interior Design

Arrangements made on the assumption they will be displayed in a living space.

Orchids must be prominent.

70 % of decorated arrangements must be orchids.

Size of Exhibit: Must fall within: width 90 cm x depth 90 cm x height 165 cm

Those exceeding the above dimensions will be excluded from the judging.

To be displayed on 75 cm-tall stand, with no side panels

*A theme will be selected for the main judging at Tokyo Dome.

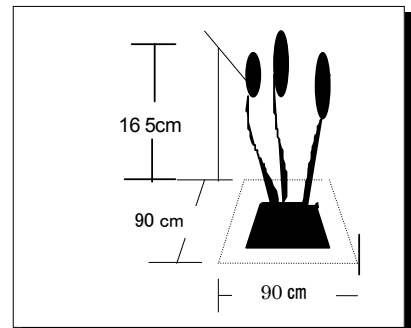

2. Table Arrangement

Arrangement must be portable and be able to fit in a living

space. It should be designed in a way that will help make orchids feel familiar in daily life

Orchids must be prominent. 70% of flowers decorated must be orchids.

Size of Exhibit: Must fall within: width 60 cm x depth 60 cm x height 90 cm

Those exceeding the above dimensions will be excluded from the judging.

To be displayed on 75 cm-tall stand, with no side panels

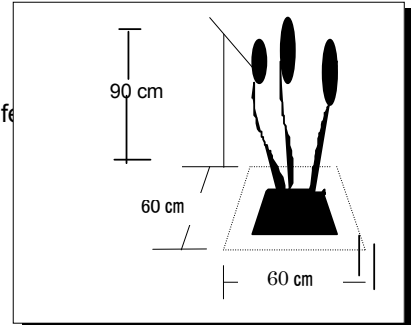

3. Bouquet

Bouquets to be designed in a new style, suitable for a living space.

70 % of flowers used must be orchids. Works must be portable.

Orchids must be prominent.

Size of Exhibit: Must fall within: width 60 cm x depth 80 cm x height 165 cm

*To be displayed on 75 cm-tall stand, with no side panels

You are requested to arrange the stand for the bouquet by yourself.

*A theme will be selected for the main judging at Tokyo Dome.

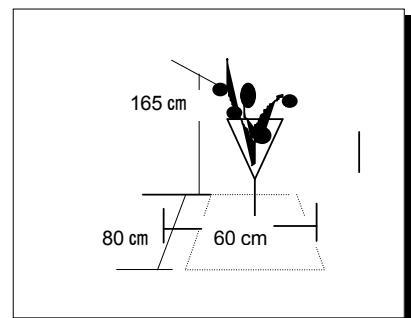

* Sizes of Exhibit Stands for the three categories.

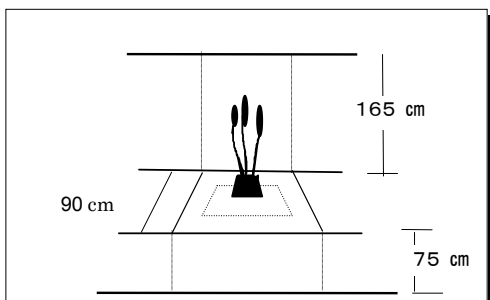

Division V. Arts and Crafts

There are seven categories in the Div. V arts and crafts.

*Please follow the regulations for works. Works we deem not to have followed the regulations will be excluded from judging.

1. Paintings

Works with orchids as the motif, such as oil paintings, watercolors, print art, ink paintings, pastel drawings, etc.

*Chigiri-e, Hari-e (pictures made with pieces of torn paper) are considered Category 7: other works.

Up to 80 cm wide and 80 cm high including picture frame. (Depth in accordance with size of picture frame).

*Works should be presented in picture frames and protected with glass or acrylic. Works stuck on the panel are not acceptable.

*State on the back of the painting which way is up.

* Works larger than the above dimensions will be disqualified.

2. Botanical artworks

Miniatures depicting plants with orchids as the motif. Should be composed of whole plants, i.e. flowers, leaves, stalks and **roots**. Up to 80 cm wide and 80 cm high including picture frame. (Depth in accordance with size of picture frame)

*Works should be presented in picture frames and protected with glass or acrylic. Works stuck on the panel are not acceptable.

*State on the back of the painting which way is up.

* Works larger than the above dimensions will be disqualified.

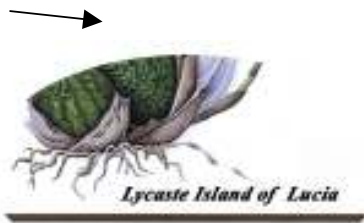

State the name of flower (genus name, and species or hybrids name).

Draw the roots.

*If you need to confirm the spelling of flower names,

3. Photographs

Photographs with orchids as the motif, color or monochrome.

Up to 80 cm wide and 80 cm high including picture frames.

*Works should be presented in picture frames and protected with glass or acrylic.

*State on the back of the painting which way is up.

* Works larger than the above dimensions will be disqualified.

Sizes of paintings, botanical arts and photographs→

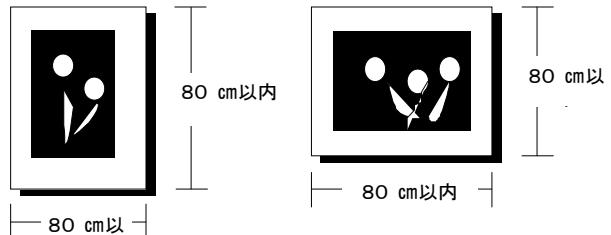

4. Artificial flowers

Artificial flowers with orchids as the motif.

Up to 70 cm wide, 80 cm deep and 100 cm high. Works larger than the above dimensions will be disqualified. Exhibits to be displayed on a 75 cm high display stand with a 165 cm high white back panel.

5. Preserved Flowers

Preserved flowers with orchids as the motif.

Up to 70 cm wide, 80 cm deep and 100 cm high. Works larger than the above dimensions will be disqualified. Exhibits to be displayed on a 75 cm high display stand with a 165 cm high white back panel.

6. Pressed or dried flowers

Pressed or dried flowers with orchids as the motif.

Up to 70 cm wide 80 cm deep and 100 cm high in case works are in the picture frame, up to 70 cm wide 80 cm deep including the picture frame.

*Exhibits larger than the above dimensions will be disqualified.

*Exhibits to be exhibited on a 75 cm high display stand with a 165 cm tall white back panel. Framed works will be hung on this back panel.

7. Other Craftwork and Fine Arts (dyeing and textiles, pottery, glass, woodcarving, metalwork, cloisonné, Chigiri-e or Hari-e and other works)

Dyeing and textiles, pottery, glass, wood carving, metalwork and cloisonné, Chigiri-e or Hari-e and other works with orchids as the motif.

Up to 70 cm wide, 80 cm deep and 100 cm high

Works in the picture frame can be up to 80 cm wide and 80 cm high including the picture frame.

* Exhibits larger than the above dimensions will be disqualified. Exhibits will be displayed on 75 cm high display stand with a 165 cm high white back panel. However framed works, works on the panels and tapestry works are to be hung on the back panel. In the event that works such as kimono - which require more width for display - exhibitors are requested to consult the head office upon submitting their application.

Notes: Exhibitors for this category are requested to fill in the application forms in detail on materials used in the work and how the work is made.

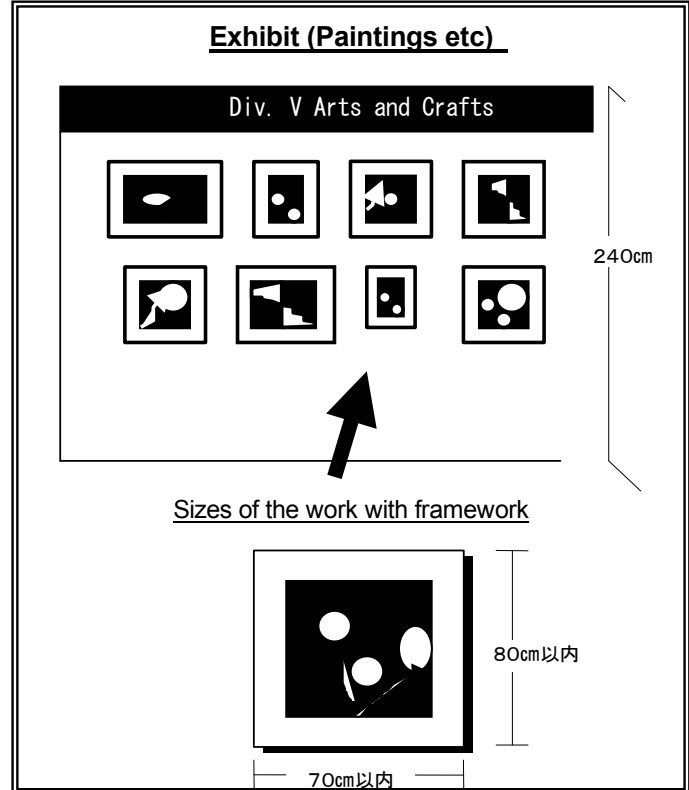
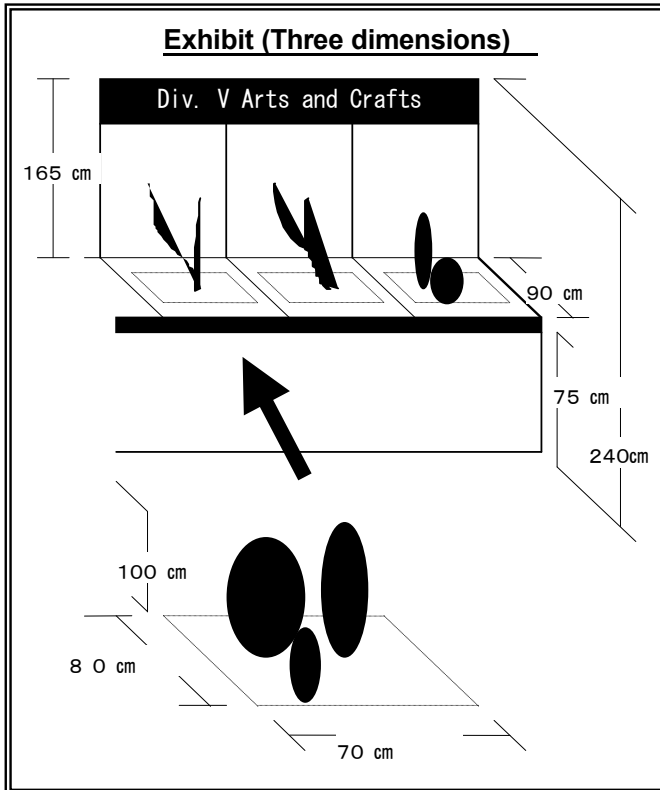

Div. VI. Miniature Orchid Garden

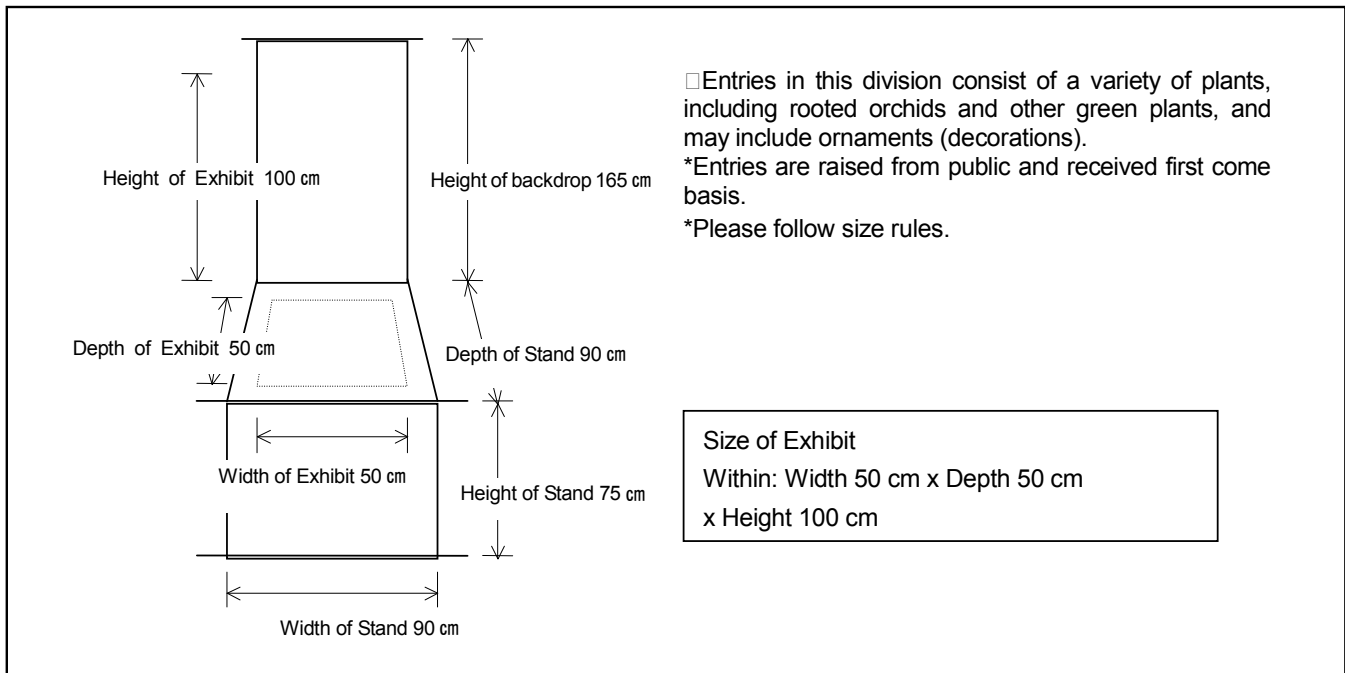

Notes:

- ◆ All flowers in the exhibits must be orchids. Flowers other than orchids cannot be used. Any orchids can be used but they must be rooted.
- ◆ Ornaments such as candles or dolls and greenery can be combined.
- ◆ This festival is held in strict accordance with the Convention on International Trade in Endangered Species of Wild Fauna and Flora. Only orchids imported in compliance with CITES will be accepted. However, plants propagated artificially from plants imported before the application of the convention (January 17, 1990) are acceptable. Please submit copies of CITES to the Show Secretariat. The Working Committee reserves the right to reject the entry of plants that are restricted to import and export by CITES or those that have been uprooted from their natural habitat and also reserves the right to inform concerned authorities of such exhibitors.
- ◆ If the decoration or the title of the exhibit offends public order and/or morals, it will not be accepted.
- ◆ An exhibit must be composed of two or more plants. There are no limits on the number of containers, but in the case of more than two containers being used, the containers must be combined.
- ◆ Works should fall within the designated sizes. There are no restrictions on container materials, but the exhibit should give visitors the impression that the main purpose of the work is to display orchids.
- ◆ The entry must be unpublished and original. Work should have made by the applicants themselves.

| Prizes | | | | | |
|---|--|-----|-------------------|----------------------------|---|
| Division IV Flower Arrangement Division | | | | | |
| Judging Category | Award | No. | Prize Money (yen) | Prize | Judging Method |
| Preliminary Judging | Entries which pass preliminary judging are to be displayed and judged at the Dome. | | | | |
| Trophy Award | Trophy Award | 12 | — | Certificate Trophy | All entries are judged. A total of twelve entries will be selected. |
| Division Award | Award for Excellence | 1 | ¥ 200,000 | Certificate Special Trophy | The twelve trophy awards will be judged and selected for division awards. |
| | Award for Distinction | 1 | ¥ 100,000 | | |
| | Merit Award | 1 | ¥ 50,000 | | |
| | Encouragement Award | 4 | ¥ 30,000 | Certificate | |

| Division V Arts and Crafts Division | | | | | |
|-------------------------------------|--|-----|-------------------|----------------------------|---|
| Judging Category | Award | No. | Prize Money (yen) | Prize | Judging Method |
| Preliminary Judging | Entries which pass preliminary judging are to be displayed and judged at the Dome. | | | | |
| Trophy Award | Trophy Award | 18 | — | Certificate Trophy | All entries will be judged. A total of eighteen entries will be selected. |
| Division Award | Award for Excellence | 1 | ¥ 200,000 | Certificate Special Trophy | The eighteen trophy awards will be judged and selected for division awards. |
| | Award for Distinction | 1 | ¥ 100,000 | | |
| | Merit Award | 1 | ¥ 50,000 | | |
| | Encouragement Award | 7 | ¥ 30,000 | Certificate | |

| Division VI Miniature Orchid Garden Division | | | | | |
|--|-----------------------|-----|-------------------|----------------------------|---|
| Judging Category | Award | No. | Prize Money (yen) | Prize | Judging Method |
| Trophy Award | Trophy Award | 12 | — | Certificate Trophy | A total of twelve entries will be selected. |
| Division Award | Award for Excellence | 1 | ¥ 200,000 | Certificate Special Trophy | The 12 trophy awards will be judged and selected for division awards. |
| | Award for Distinction | 1 | ¥ 100,000 | | |
| | Merit Award | 1 | ¥ 50,000 | | |
| | Encouragement Award | 3 | ¥ 30,000 | Certificate | |

*For the Division Award winners, special trophies are given in addition to trophies for the Trophy Award.

How to apply

Division IV Flower Arrangement

Exhibitors are requested to fill out the enclosed application form and attach a picture of their work over the last 12 months (work of the same genre) and sketches of work to be exhibited at the show. Please send applications to the Head Office, along with ¥2000 per entry, no later than November 12, 2010. The fee payment must be in cash. If the exhibitor lives outside Japan, a ¥2000 international money order should be enclosed, available from post offices.

*Keep a copy of the application.

*In preliminary judging, the outlines of your works in the picture and the sketch will be judged. The sketch is for preliminary judging. The design of the work can be changed from the original sketch at Tokyo Dome as necessary. The sketch must be drawn by the exhibitor. Other sketches will not be accepted.

Division V Arts and Crafts: Paintings, Botanical Artworks and Photographs

Exhibitors are requested to fill out the enclosed application form and attach a picture of the work to the form. Please send applications to the Show Head Office, along with ¥2000 per entry, no later than November 12, 2010. The fee payment must be in cash. If the exhibitor lives outside Japan, a ¥2,000 international money order should be enclosed, available from post offices. If the exhibitor is coming to Japan during the festival period, payment at the show is acceptable. In this case, please contact us in advance.

*Send a picture of the work that you are going to enter for the judging. This is for the primary judging. If successful, we will send the information in December for main judging at Tokyo Dome. We cannot return the picture. Thank you very much for your understanding.

Division V Artificial Flower / Preserved Flowers / Pressed and Dried Flowers / Other Craftwork and Fine Arts (Dyeing and Textiles, Pottery, Glass, Woodcarving, Metalwork, Cloisonné, Chigiri-e & Hari-e and others)

Exhibitors are requested to fill out the enclosed application form and attach a picture of the work to it. Send it to the Head Office with ¥2000 per entry no later than November 12, 2010. The fee payment must be in cash. If the exhibitor lives outside Japan, a ¥2,000 international money order should be enclosed, available from post offices.

*For entries of Artificial Flowers, Preserved Flowers, send a picture of work from the last 12 months (work of the same genre). For entries of Pressed and Dried Flowers, and other Craftworks and fine Arts, send a picture of the work to be entered in the main judging.

* In preliminary judging, the outline of works in the pictures will be judged.

*Keep a copy of the application.

Division VI Miniature Orchid Garden

Fill out the application form and submit it no later than Friday, November 12, with ¥2,000 yen as entry fee.

Deadline: Friday, November 12, 2010

for the Application of Division IV Flower arrangement, Division V Arts and Crafts & Division VI Miniature Orchid Garden

Schedule of the Year

| | | |
|------|---|--|
| 2010 | Friday, August 2 | Information on entries from public for Flower Arrangement, Arts and Crafts and Miniature Orchid Garden are released. We receive applications from general Public for these three Divisions. |
| | Friday, November 12 | Deadline for Applications Registration Fee for Preliminary Judging ¥2000 (Div. 4 & 5) |
| | November 26 | Preliminary Judging for Flower Arrangement, Arts and Craft Result Announcement |
| | Middle of December | Registration for Main Judging, Registration Fee for Main Judging ¥1,000 |
| 2011 | Middle of January | Final Notice is sent. |
| | Wednesday, February 16 Thursday, February 17 | Setting up of Exhibit (Painting, Botanical Art, Photograph are exhibited by organizer) Registration and Exhibit: February 16, 4 p.m.-7 p.m. / February 17, 11 a.m-3 p.m. *for the Flower Arrangement set-up, site is open till 10 p.m. on February 16 and 8 p.m. on February 17. |
| | Friday, February 18 | Main Judging, Opening Ceremony, Preview |
| | Saturday, February 19 – Sunday, February 27 | 【JGP 2011】 February 27 from 6:30 p.m.-9:30 p.m. Removal of the works |

Others

Preliminary Judging for Flower Arrangement and Arts and Crafts

There is limited exhibition space at Tokyo Dome, so not all works for which applications are submitted can be exhibited. Preliminary judging will take place, and only entries that are successful will be exhibited at the Japan Grand Prix International Orchid Festival 2011 and proceed to the main competition. Preliminary judging will be held at the end of November. Results will be mailed at the end of November, after preliminary judging.

Main judging at Tokyo Dome

For the Division IV flower arrangement, a theme will be selected for the judging criteria. Details will be circulated after preliminary judging.

Setting up at the site

On February 16 and February 17, 2011, exhibitors set up their exhibits and entries are registered for judging. On February 18, judging will proceed and works to receive awards selected.

*Works in the categories of paintings, botanical arts, pictures must be sent to the secretariat beforehand - exhibitors do not have to come to the show to display the work.

* Details will be sent after preliminary judging.

Notes

- ◆Rules for exhibitors should be strictly observed. Any exhibit that infringes the rules will not be accepted.
- ◆This festival is an orchid show. The following must be noted.
 - Flower Arrangement - More than 70 % of flowers must be orchids.
 - Arts and Crafts - The motif must be orchids.
 - Miniature Orchid Garden - All flowers to the exhibit must be rooted orchids.
- ◆Forms must be submitted by the closing date. Submissions received after the closing date will not to be accepted.
- ◆Entry is limited to one exhibit per person in each category. Entries by an exhibitor to more than one category are acceptable.
- ◆All entries at the show will be judged.
- ◆Works of flower arrangement must be maintained by exhibitors during the festival period, so please consider that exhibitors will need to come to the show during the festival.
- ◆Individual lighting cannot be provided. However, electricity for works of lamps (Div. 5) is available provided it is requested beforehand. (Electricity is available subject to fees.)
- ◆Incomplete application forms cannot be accepted. Please complete all of the forms. Columns for work records on the back are also to be filled out.
- ◆Please do not cancel an application after it has been submitted. The judging fee is nonrefundable. The judging fee is not refunded once preliminary judging has taken place.
- ◆The name of the exhibitor must be the individual exhibitor's. In the case of joint work, up to three names can be registered. A company name or a group name cannot be used.
- ◆In the display area, PR activity is not acceptable and PR materials cannot be distributed.
- ◆Works must be original and previously unpublished.
- ◆We do not take responsibility for any damage or accidents during delivery and displaying at the site. Please take out insurance if necessary. Please consult with the individual delivery company about their policy on damage or accidents during delivery.
- ◆Though exhibits at the venue are maintained by the show organizer, in case of fire, theft, and other accidents we do not accept liability for any damage.
- ◆The host may decide to suspend or cancel the festival due to an act of god or for other unavoidable reasons. Please note that damage or loss you suffer derived from such action shall not be compensated for by the host.

Sales Products

The following products can be sold at the show. Please indicate the name of the flower, contact address and telephone number on each product so that customers can contact you directly. (Note: Sales of products that do not lend themselves to the spirit of the show or are illicit are prohibited, as are sales that disrupt normal operations.)

A: Cultivated orchids (potted plants, cut flowers, seedlings)

→ Plants other than orchids cannot be sold by themselves separately.

◆ Only plants imported following the proper procedures of CITES I or II can be sold. If you import orchids listed in CITES Appendix I, you need to get an import permit issued by Japanese government. If you do not know anyone who can arrange the relevant permits in Japan, please contact the show secretariat. With regard to CITES I, II documentation please fax them in advance or prepare copies for us and submit the documents themselves at the show.

◆ Only cultivated orchids can be sold. Sales of wild orchids are prohibited.

◆ Diseased plants, defective plants, or plants that are difficult to grow are not permitted to be sold.

◆ Plants that are fumigated cannot be sold.

◆ Preserved flowers belong to Category C products, which use orchids as materials or have orchid motifs.

B: Items related to horticulture

→ Compost, bark, moss, fertilizer, chemicals, greenhouses, pots, gardening related publications

◆ Orchids can be displayed and sold provided they comprise no more than 30% of the products displayed at a sales booth.

C: Products using orchids as materials or with orchid motifs (The products must be cleared by secretariat.)

→ Food, textiles, clothing, interior decorations, ornaments, jewelry, stationery, postcards, prepaid cards, etc.

◆ Products in the same product line but without an orchid connection can take up to 30% of the displayed products.

◆ If you are selling food, you are requested to make special arrangements based on the food hygiene law. Eating and drinking, including tasting, are prohibited inside the arena.

Sales Period

Evening of the preview day: Friday, February 18 (5:10 – 8:30 p.m.)

Hours open to public (10 a.m.-5:30 p.m.) from Saturday, February 19, to Sunday, February 27, 2011.

*Please bring sufficient products for sale to ensure your sales booth remains open until the end of the last scheduled day.

*The hours of the festival might be extended. This has yet to be determined. Thank you very much for your understanding and cooperation.

*In addition to the above extended hours, the festival may be remain open for additional hours for private groups who make reservations to see the festival in the evening (up to 8:30 p.m. at the latest).

Conditions

Participation in the display division is desirable if you intend to sell plants.

◆ If you would like to share a booth with more than two vendors, please contact the head office.

◆ If you are a vendor of variety goods and not handling plants, you can have a sales booth for Overseas discount rate by entering three artworks in the Div. V (Arts and Crafts Division). You cannot enter more than two works in any category, but must enter in three categories.

◆ You can also operate only a sales booth, the fee for which is ¥630,000.

◆ You are requested to place an ad in the festival brochure for ¥50,000.

* Information on orchids and vendors of products

The organizers cannot answer inquiries (on cultivation methods, etc.) from customers. Please attach labels on each plant so that customers will know where the products are from and how they can contact you. If you do not have labels on your products, you will be requested by the inspection committee to close your sales booth or remove the products. **Please send us a sample of your labels with your application form. Applications without labels will not be accepted.**

(A: Cultivated orchids) Genus name, species or hybrid name, vendor name, address, telephone number, should be printed on the labels. Put labels on each product. Using business cards or brochures instead of labels is prohibited. Printing should be clear and should not become difficult to read with time.

(A: Cut flowers) Genus name, vendor name, address and telephone number must be printed on stickers or wrapping paper for each product. Stickers indicating above information are acceptable.

(B: Items related to horticulture; C: Products using orchids as materials or with orchid motifs) Vendor name, address, telephone number should be printed on stickers. Put the stickers on each product. Business cards or brochures can also be used for this purpose.

B/c. Pamela Hetherington
'Coronation'

New York Orchid Nursery
10 JGP Ave. New York 2010 USA TEL 03-6739-6940

Fee for Sales Booth

Fees for Overseas exhibitors those who are participating in the Division III Display are followings. (Entries must first be accepted for judging.) The fee is ¥630,000 per booth for those who choose only to run a sales booth.

| Exhibitors | First Booth | Second Booth | Third Booth | Garbage Disposal Fee | Ad Insert Fee |
|----------------------------------|-------------|--------------|-------------|--|---------------|
| East Asia (China, Korea, Taiwan) | ¥367,500 | ¥315,000 | ¥315,000 | ¥15,000 (¥20,000 for more than two booths) | ¥50,000 |
| Other Area | ¥315,000 | ¥315,000 | ¥315,000 | | |

The ad space rate in the guidebook is ¥50,000, Please note that exhibitors using sales booths are obliged to contribute to the vendor information pages in the official guide book.

Specification of Brochure (tentative): A4 size (210-294mm), 4-color printing
Size of insertion (tentative): 37(vertical) x 62(wide) mm

How to submit the artwork and the specifications of the guidebook will be notified separately. If you order artwork, it is subject to fees.

Specifications

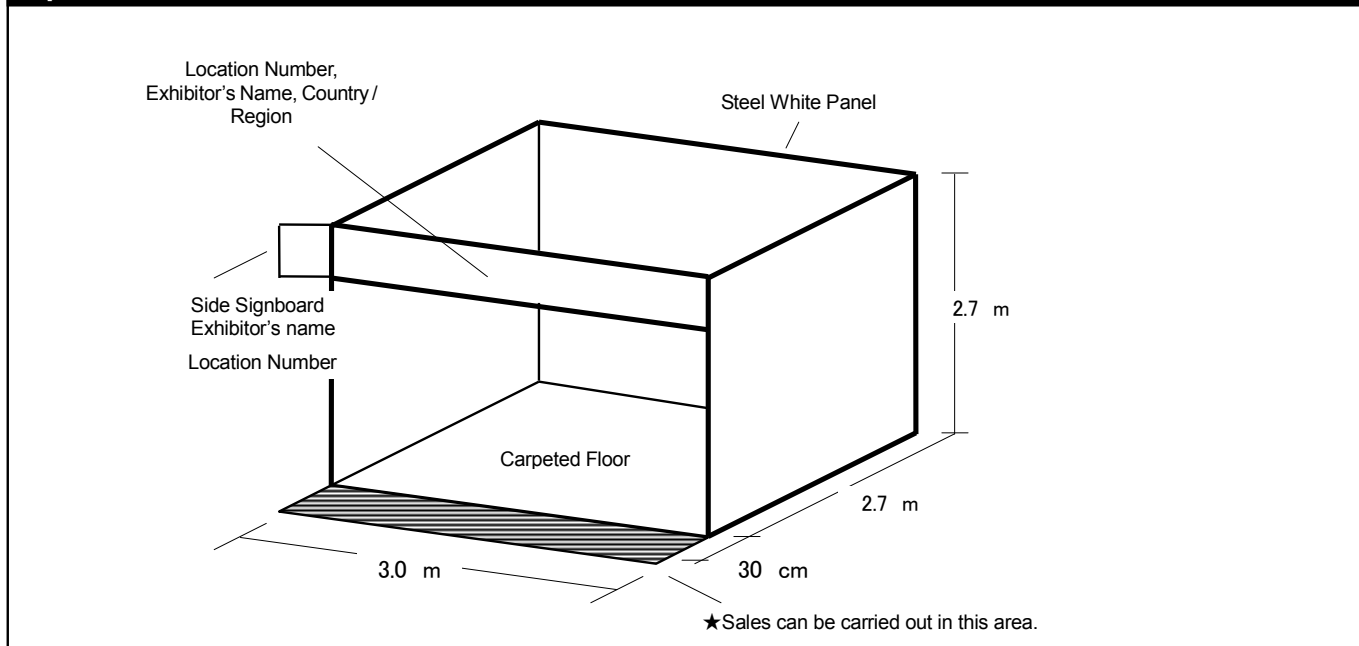

Size: Width 3.0 m x Depth 2.7 m x Height 2.7 m / steel panel / white

On the signboard the location number, exhibitor's name, country or region are stated. Explanatory suffixes such as Co., Ltd. or Inc. should be omitted. The panels are steel and thumbtacks or nails cannot be used on them. Rental shelves, counters etc. are available, please refer to the order forms, which will be sent in November. Also lighting equipment, electrical works, and other rental equipment can be ordered using the same order forms. It is possible to sell products in front of the booth, but only within 30 cm of the booth.

How to Apply

Please fill in the Division III Display / Sales Booth Application Form, Sales Product List, the written declaration and send them with a sample of labels to the address below by September 3, 2010.

Head Office of Japan Grand Prix International Orchid Festival
c/o THE YOMIURI SHIMBUN

1-7-1 Otemachi, Chiyoda-ku, Tokyo 100-8055 Japan

Contact Person: Nanako Terakubo Tel: +81-3-6739-6940; Fax: +81-3-3216-8568. tera9130@yomiuri.com

- ◆Applications arriving after the deadline or those with missing information will be placed on a waiting list.
- ◆Admission fees are paid by visitors to enjoy exhibits, therefore vendors who participate in the Div. III display will be given priority over those participating as vendors only.
- ◆Applications will be accredited by the organizing committee taking into account past participation and the content of applications.
- ◆Applications will not be accepted from vendors who have committed an infringement (such as selling imports prohibited by CITES, infected plants, wild plants, those of inferior quality, or products without the required labels detailing the information on orchids and vendors).
- ◆Exhibitors who have had their exhibits rejected by judges in previous years or who have committed an infringement will not be allowed to participate.

Garbage Disposal

When disposing of garbage, you will need to use designated garbage stickers on the plastic bags. Please separate the garbage into combustible and noncombustible items, and place it in the designated plastic bags. Garbage stickers must be placed on the bags, with the exhibitor's name clearly marked. Also for cardboard boxes you will also need to use stickers. A maximum of 10 cardboard boxes can be thrown out with one sticker. Please bundle carton boxes together. The stickers are available at the exhibition office for ¥500 for each.

Vendors will be provided with 10 stickers for each kind of garbage (combustible and noncombustible) for their first booth and 20 stickers for each (combustible and noncombustible) for vendors with more than two booths.

Cancellation

***If you wish to cancel your entry, please notify us at once. You are requested to pay the following cancellation fees.**

Cancellation between Friday, January 28, and Friday, February 10, 2011: 50% of sales booth fee

Cancellation on or after Saturday February 11, 2011: 100% of sales booth fee

Booth Fee Payment

Invoices for booth fees will be sent out in November.

Please make a remittance to the designated bank account by Friday, January 28 2011.

Payment at the exhibition in cash will also be accepted from those who have participated in the JGP in the past.

Schedule

| | | |
|------|--|--|
| 2010 | August | Registration for display and sales starts. After receipt of application, notice of receipt will be sent. |
| | Friday 27 August | Deadline for domestic exhibitors Application for display and sales |
| | Friday 3 September | Deadline for overseas exhibitors Application for display and sales |
| | Mid-October | Layout of display and sales booths decided |
| | Beginning of November | Sales of advance tickets starts |
| | Tuesday November 9 1:30-3:30 p.m. | Orientation Meeting for Domestic Exhibitors at THE YOMIURI SHIMBUN, |
| | Mid- November | Orientation kits sent to exhibitors. Information on display, sales and judging finalized. List of exhibitors, entry application forms prepared. |
| | November 26 | Deadline for information pack requests |
| 2011 | Friday January 7 | Deadline for entry forms |
| | Mid- January | Deadline for final confirmation of orchid delivery schedule For your export schedule to Japan, the following information is required: Dates, items to be shipped, number of items, method of shipping, flight number, port of entry, etc. This information will be forwarded to transportation companies, customs, and plant quarantine to ensure smooth customs clearance and other import procedures. |
| | Mid-January | Final Notice |
| | Saturday February 19 Sunday February 27 | JGP 2011 |

Extended Hours

*Please prepare sufficient products for sale so your sales booth can stay open until the end of the last scheduled day.

*The hours of the festival might be extended. This has yet to be determined. Thank you very much for your understanding and cooperation.

*In addition to the above extended hours, the festival may remain open for additional hours for private groups who make reservations to see the festival in the evening (up to 8:30 p.m. at latest).

Notes

◆Wild plants, diseased plants, inferior quality plants, plants that violate CITES, products without information labels and other inappropriate products put up for sale will be removed by the inspection committee.

◆Sales staff must be trained in serving customers and have knowledge of the products on sale.

◆Prices must be decided within the market price range. Prices must be marked on each product.

◆All vendors must purchase shopping bags from the secretariat and use them for sales to prevent theft. The shopping bags should be ordered in November.

◆You are requested to fill out and submit the "Written Sales Declaration." It is a declaration stating that you are responsible for sales, that you will not cause problems and that you will follow the rules of the festival.

◆Ensure you have sufficient products for the nine days of the festival so that you do not have to close your booth early.

◆If you are selling food, you are requested to make special arrangements based on the food hygiene law. Eating and drinking, including tasting, are prohibited in the arena.

◆In the case of a group entry in the Division III display, each vendor in the group will not qualify for a discount on separate sales booths unless the secretariat grants special permission.

◆Plants that are fumigated with methyl bromide at customs cannot be sold because the fumigation process damages flowers severely, leading to customer dissatisfaction and problems. Please take sufficient precautions before sending products to Japan.

◆We do not take responsibility for any damage or accidents during delivery and display at the site. Please buy insurance to cover your needs. As for damage or accidents sustained during delivery, consult the relevant delivery company.

◆Though exhibits at the venue are guarded and maintained by the show organizer, in case of fire, theft, and other incidents, we will not accept any liability for damage.

◆The host may decide to suspend or cancel the festival due to an act of God or for unavoidable reasons. Such a decision will be announced in Yomiuri Shimbun publications or on the Web site of JGP. Please note that the host will not provide compensation for any damage or loss incurred as a result of such a decision.

Orchid Export to Japan

All orchids are subject to the provisions of the Convention on International Trade and Endangered Species of Wild Fauna and Flora, excluding seedlings or tissue cultures obtained in vitro in solid or liquid media transported in sterile containers.

CITES permits, phytosanitary certificates, invoices and packing lists are required to export orchids to Japan.

*CITES permits

For orchids subject to Appendix II, only CITES permits issued by the government in your country are required.

For orchids subject to Appendix I, in addition to the CITES permit issued by the government in your country, you will need to obtain a permit to import the orchids issued by Japanese government. (See details below.)

*Phytosanitary Certificate

A phytosanitary certificate issued by plant inspectors in your country is necessary for all orchids imported.

*Invoice

Plant names, value of all plants, numbers of plants shipped, and consignee must be mentioned.

*Packing List

It must be very clear which plants are in which boxes and how many plants are in the boxes. For this purpose, we need packing lists for each box.

If you are not sure which forwarder you should use, we recommend Nippon Express for your transportation needs. They will arrange cargo, customs clearance, and transportation from the relevant airport to Tokyo Dome. For details (costs etc), refer to the information provided in November.

Orchid Export from Japan

The same documentation as above is necessary for those planning to export orchids from Japan. If you apply for a CITES permit no later than Tuesday, February 16, we can take care of the CITES paperwork. Please apply using the relevant form sent out in November. As a lot of paperwork is required to apply for a CITES permit, early applications are appreciated.

Information on Convention on International Trade in Endangered Species of Wild Fauna and Flora : Appendix I

Be sure to apply for an import permit. Submit in advance the copies of the CITES export or import permit to the exhibition secretariat. If you import plants for another purpose, be sure to obtain a separate CITES permit for them from the one intended for the plants to be sold at the JGP festival.

The orchid species subject to CITES Appendix I (artificially propagated plants only), for which import permits are required, are as follows:

Aerangis ellisii
Dendrobium cruentum
Laelia jongheana
Laelia lobata Paphiopedilum spp.
Peristeria elata
Phragmipedium spp.
Renanthera imschootiana

Documents to be submitted in applying for import permits are:

- Copy of CITES (the expression "artificially propagated" should be specified in the document)
- Invoice (quantity, description, unit price, total amounts are stated) *You are the consignee. Consignee's address is: Tokyo Dome, Japan Grand Prix International Orchid Festival 2010, 1-3-61 Koraku, Bunkyo-ku, Tokyo 112-8575
- Letter of attorney to an agent or acquaintance in Japan who would apply for an import permit
- Application form for import acknowledgment (forms provided by Japanese government)
- Information form for import permit (forms provided by Japanese government)

If you don't know anyone who can take care of this paperwork, contact us by the end of November. We can introduce a nursery that can take care of the paperwork. You will be charged for expenses involved in doing this.

*Pre-acknowledgment is required for orchids subject to Appendix II imported from Afghanistan, Guinea, India, Israel, Papua New Guinea, Peru or the Philippines. In this case we also need an application.

Admission**《Price》**

Advance tickets: ¥1,800

Door tickets: ¥2,000

Evening tickets: ¥1,500 (* sold only at the door on the day after 3 p.m.)

※Grade school children or younger: Free

《Sales Period》

Advance tickets available from the beginning of December 2010 through Friday, February 18, 2011

Door tickets available from Saturday, February 19, to Sunday, February 27, 2011

Ticket Sales for Exhibitors

Discount rates for exhibitors are as follows:

| | | |
|-------------|-------|--------|
| ●Exhibitors | Adult | ¥1,100 |
| ●Only Sales | Adult | ¥1,620 |

These tickets are available only prior to the show. Minimum order is 30 tickets.

Please sell these discounted tickets at the fixed price of ¥1,800 if you sell them to a third party.

For further Information

Japan Grand Prix International Orchid Festival
 c/o THE YOMIURI SHIMBUN, 1-7-1 Otemachi, Chiyoda-ku Tokyo 100-8055 Japan
 Contact: Nanako Terakubo
 Tel: +81 3-6739-6940; Fax: +81 3-3216-8568 tera9130@yomiuri.com

- * We are going to move to the following address on Monday, September 27 2010.
 6-17-1 Ginza Cyuoku Tokyo 104-8243
 Tel number, fax number, email address will be the same.